

Magnetic Sensor IC

Unipolar Detection High Performance Hall-Effect Sensor IC



AS1797

● General Description

Using BiCMOS process, the AS1797 is designed for high performance unipolar detection hall-effect application, such as home appliances, rotor position sensing, brushless DC motor etc. The hall IC integrated an on-chip hall voltage generator for magnetic sensing, a comparator that amplifiers the hall voltage, hall sensor with dynamic offset cancellation system, an pull-up resistance, and a Schmitt trigger to provide switching hysteresis for noise rejection, and a voltage regulator for operation with supply voltage of 2.5V to 24V.

AS1797 is designed to respond to alternating North or South poles. While the magnetic flux density (B) is larger than operate point (B_{OP}), the output will be turned on (low), the output is held until the magnetic flux density (B) is lower than release point (B_{RP}), then turn off (high).

The device is available in SIP-3L and SOT23-3L Package and is rated over the -40°C to 125°C . the package is RoHS compliant.

● Features

- High Performance BiCMOS Process Tech.
- Input Voltage Range : 2.5V to 24V
- Resistant to physical stress
- Unipolar Latch Operation
- High Sensitivity Hall Sensor
- High Chopping Frequency
- Magnetic Sensitivity (typical)
 $B_{OP}=110\text{Gauss}$, $B_{RP}=80\text{Gauss}$
- Need Pull-up Resistance
- Reverse Voltage Protection: -24V
- Over Voltage Protection: 24V
- Small Solution Size
- RoHS Compliant
- SIP-3L and SOT23-3L Packages
- -40°C to $+125^{\circ}\text{C}$ Temperature Range

● Applications

- Electric Tools
- Automotive, Home appliances, Industrial
- Rotor Position Sensing and Flow Meters
- Brushless DC Motor/Fan
- Speed Measurement
- Revolution Counting
- Valve and Solenoid Status
- Proximity Sensing
- Tachometers
- Magnetic Encoder

■ Ordering Information

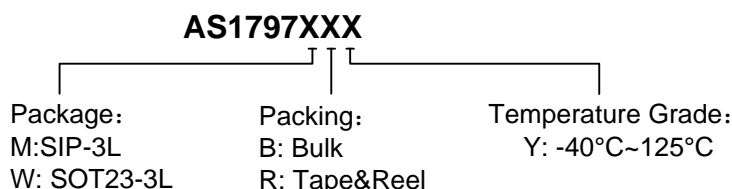

Part Number	B_{OP}/B_{RP} (Gauss)	Package Type	Package Qty	Temperature	Eco Plan
AS1797MBY	110/80	SIP-3L	1K/Package	$-40\sim 125^{\circ}\text{C}$	RoHS
AS1797WRY	110/80	SOT23-3L	7-in reel 3000pcs/reel	$-40\sim 125^{\circ}\text{C}$	RoHS

■ **Marking Information**

SIP-3L

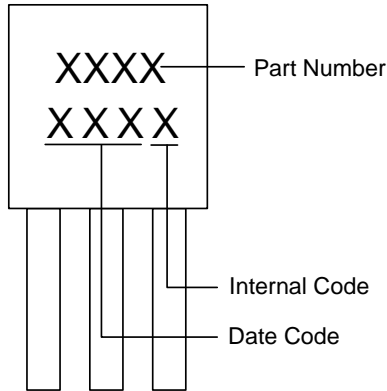

SOT23-3L

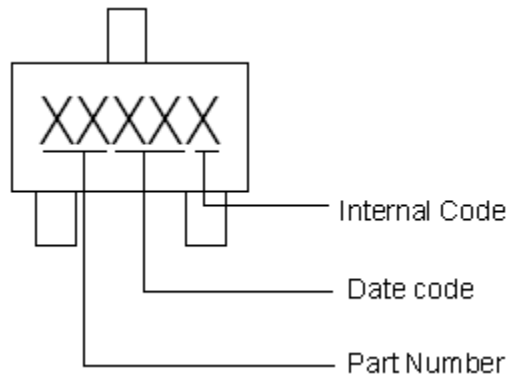

■ **Typical Application Circuit**

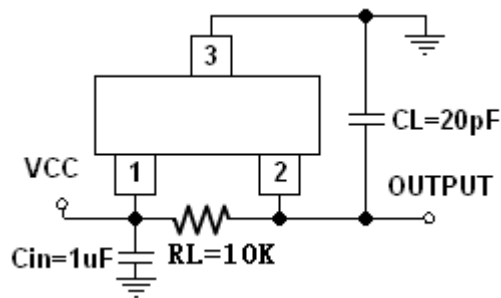
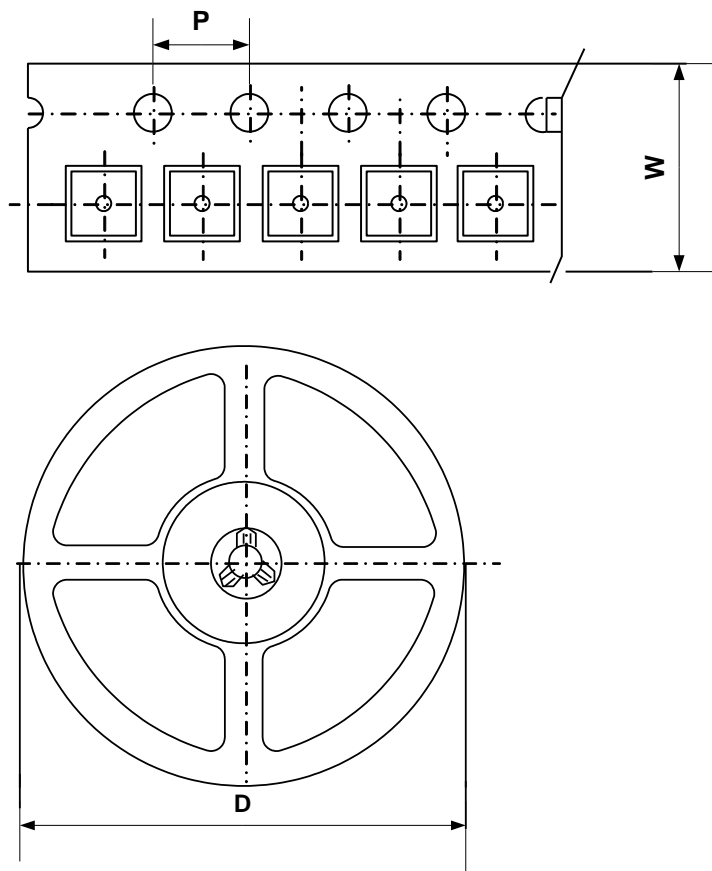

Figure 1, Typical Application Circuit of AS1797

■ **Packing Information**

SOT23-3L



Package Type	Carrier Width (W)	Pitch (P)	Reel Size(D)	Packing Minimum
SOT23-3L	8.0±0.1 mm	4.0±0.1 mm	180±1 mm	3000pcs

Note: Carrier Tape Dimension, Reel Size and Packing Minimum

■ **Packing Information**

1. Packing type: Bulk
2. Packing minimum: 1000pcs