

Magnetic Sensor IC

## Dual Outputs for both S and N-pole Low Power Hall-Effect Sensor IC



### AS1826A

#### ● General Description

Using low power CMOS process, the AS1826A is designed for low power, high performance unipolar detection dual output hall-effect application, such as cover switch, contactless switch, solid state switch and lid close sensor etc battery operation. The hall IC integrated an on-chip hall voltage generator for magnetic sensing, a comparator that amplifies the hall voltage, a chopper amplifier, a Schmitt trigger to provide switching hysteresis for noise rejection, and two complementary output.

The total power consumption of AS1826A is typically less than 3.0uA at 1.8V power supply. AS1826A is designed to respond to alternating North and South poles. While the magnetic flux density (B) is larger than operate point (B<sub>OP</sub>), the output will be turned on (low), the output is held until the magnetic flux density (B) is lower than release point (B<sub>RP</sub>), then turn off (high).

The device is available in DFN1014-4L and SOT343 Package and is rated over the -40°C to 85°C. The all packages are RoHS and Green compliant.

#### ● Features

- Input Voltage Range : 1.6V to 5.0V
- Micro-power consumption ideal for battery power applications
- Unipolar Operation, dual output
- Very high sensitivity hall sensor
- Low Power CMOS process technology
- Chopper stabilization amplifier stage
- Magnetic Sensitivity (typical)  
B<sub>OPS</sub>=26Gauss, B<sub>RPS</sub>=16Gauss  
B<sub>OPN</sub>= -26Gauss, B<sub>RPN</sub>= -16Gauss
- Good RF noise immunity
- No need pull-up resistor
- Small Solution Size
- RoHS & Green Compliant
- DFN1014-4L & SOT343 Packages
- -40°C to +85 °C Temperature Range

#### ● Applications

- Cover switch in clam-shell cellular phones
- Cover switch in Notebook, PC/PAD
- Contact-less switch in consumer products
- Solid State Switch
- Handheld Wireless Handset Awake Switch
- Lid close sensor for battery-powered devise
- Magnet proximity sensor for reed switch replacement in low duty cycle applications
- DV, DSC, and White Goods

#### ■ Ordering Information

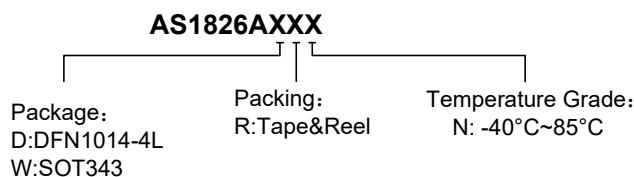

Part Number	B <sub>OP</sub> (Gauss)	B <sub>RP</sub> (Gauss)	Package Type	MSL Level	Package Qty	Temperature	Eco Plan	Lead
AS1826ADRN	±26Gauss	±16Gauss	DFN1014-4L	MSL1	7-in reel 3000pcs/reel	-40~85°C	Green	Cu
AS1826AWRN	±26Gauss	±16Gauss	SOT343	MSL1	7-in reel 3000pcs/reel	-40~85°C	Green	Cu

■ **Marking & Pin Assignment**

**DFN1014-4L**

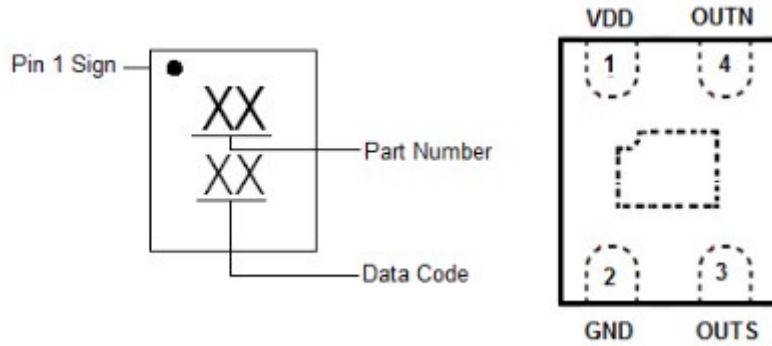

Pin Name	Pin No.	I/O	Pin Function
	DFN1014-4L		
VDD	1	P	Input Power Supply.
GND	2	P	Ground.
OUTS	3	O	Output Pin for South Pole.
OUTN	4	O	Output Pin for North Pole.

**SOT343**

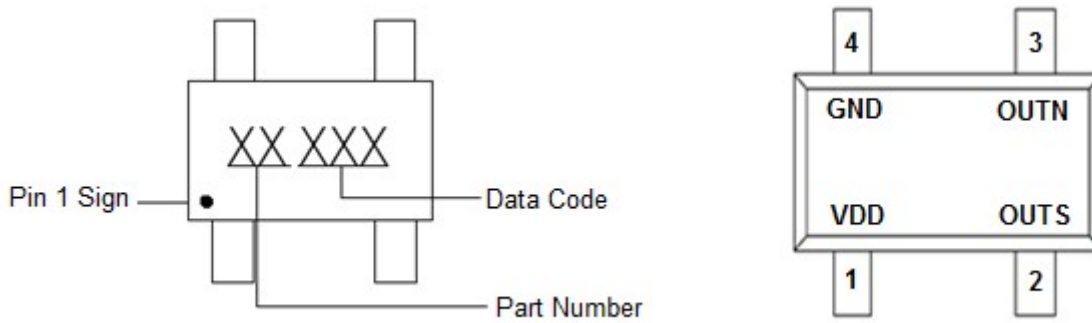

Pin Name	Pin No.	I/O	Pin Function
	SOT343		
VDD	1	P	Input Power Supply.
OUTS	2	O	Output Pin for South Pole.
OUTN	3	O	Output Pin for North Pole.
GND	4	P	Ground.

■ **Typical Application Circuit**

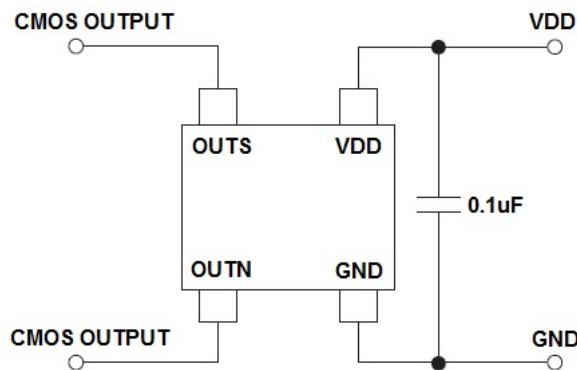
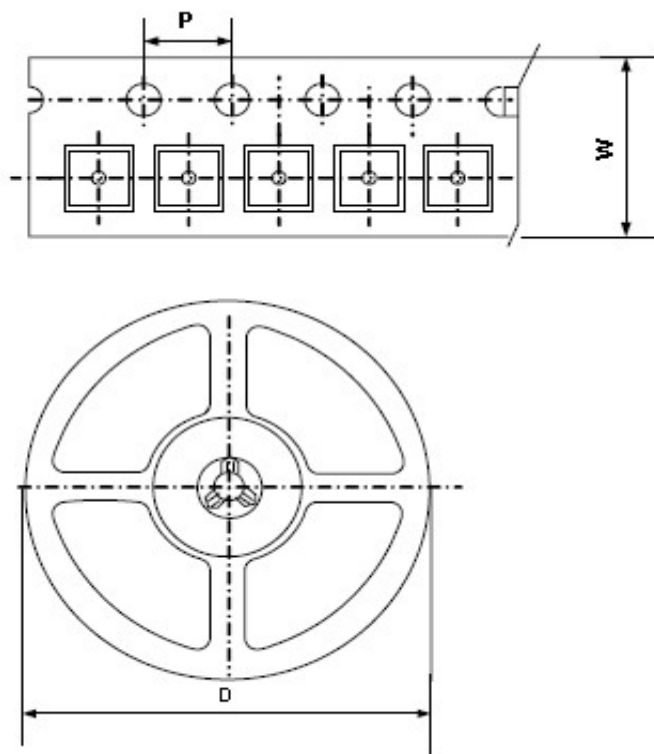
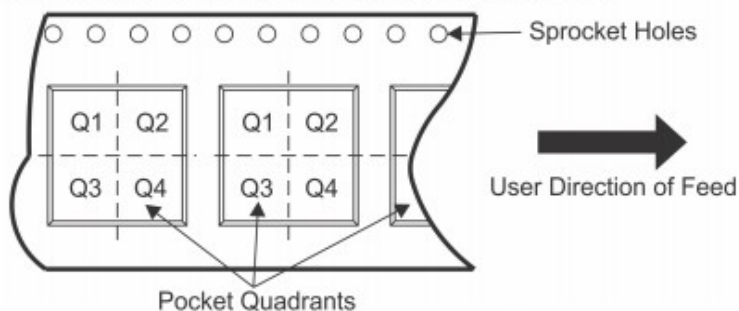

Figure 1, Typical Application Circuit of AS1826A

■ **Tape and Reel Information**



**QUADRANT ASSIGNMENTS FOR PIN 1 ORIENTATION IN TAPE**



Device	Package Type	SPQ	Carrier Width (W)	Pitch(P)	Reel Size(D)	Pin1 Quadrant
AS1826ADRN	DFN1014-4L	3000pcs	8.0±0.1 mm	4.0±0.1 mm	180±1 mm	Q2
AS1826AWRN	SOT343	3000pcs	8.0±0.1 mm	4.0±0.1 mm	180±1 mm	Q1

\*All dimensions are nominal